



STOPPING TROUBLE ON THE SPOT

Good inspection practices, typical schedules and potential problems well spotted



Welcome to the first 'Safety Spot' of 2012. I hope that you had a great Christmas and are well enough rested to meet the particular challenges that the New Year will undoubtedly throw at you. We live in interesting times – turbulence in the UK economy will, for most of us I suspect, require a period of belt tightening. It is worth remembering that it doesn't cost a lot to do thorough inspections on your aircraft and, even if you are not flying your machine as much as you would like, regular, time-based inspections are essential if you want to keep your machine in tip top condition.

A normal inspection schedule on a small light aircraft would be based upon a 50/100 hour cycle. The 50-hour check is basically a good general inspection and an engine oil and filter change; depending on usage it's often worth checking the brake linings. The 100-hour check is a 'panel off' inspection and that includes the engine cowlings. In this check, the whole airframe is given the once over with all the bearings being cleaned, inspected and relubricated. Something often

forgotten, for all sorts of reasons, is the magneto check each 100 hours; because the back of the magneto has to come off to check the condition of the points and the internal timing, there will be a need to call on the services of an LAA Inspector. With the magneto check, the condition and function of the ignition harness is checked and, don't forget, the sparking plugs will need to come out to be cleaned and gapped. With a little choreography the inspector may not need to be around for longer than an hour; as the pilot/owner you are permitted to remove and refit the panels, so he/she will only need to check that the complex operations have been completed correctly.

It's always a good idea to have a second person checking your work; two pairs of eyes are better than one. In terms of 'calendar' inspections, personally I would do a 50-hour inspection on a monthly basis, whether the aircraft had flown or not, but would keep the engine oil change and service times for specific components (for example propeller/magneto internal checks) on an hourly basis. In effect, the annual check is just a big 100-hour check with some addition requirements, for example, wheels-off bearing

checks and checks of suspension. If appropriate, undercarriage retraction checks will be carried out during the 100-hour check.

You will know by now, I should imagine, that many of the de Havilland types will soon be able to transfer to a Permit to Fly should the owners want to do so. Knowing that more complex types were very likely to be allowed to transfer from a Certificate of Airworthiness – regular readers will know that the Stampe transferred early last year – the LAA has been concentrating its efforts in redefining what we mean by scheduled maintenance and, importantly, what we expect from owners. What we wouldn't expect from aircraft owners that do decide to transfer is that their maintenance standard will drop. To quote Mark Miller, the Chief Engineer of de Havilland Support, "We would expect the standard of continuing airworthiness to rise, not fall, as owners will be far more likely to put their hand up to problems."

I think that it is definitely the case that the LAA is more able to offer maintenance solutions than an authority hamstrung by having to stay within a narrow Type definition.

In last month's 'Safety Spot' I talked about a couple of

serious incidents that befell LAA members which were, I hope that you will agree, completely preventable. In this issue I will explore a few problems that were spotted before any problems arose. In the first item, good inspection practices almost certainly prevented an engine failure after take-off.

RANS S10 KIMPEX PRIMER BULB

I'm getting a bit of a reputation here at LAA Engineering HQ, people are starting to talk. "What are those strange packages that keep arriving for Malcolm?" I hear the whispers, "They're never from the same place, and "That last one had a strange feel to it," and, "We'd better keep an eye on him..."

It's true, I do like receiving presents, and I do get a fair number of small, unmarked packages. Nothing sinister though, I'm not a closet collector of, well let's just say, 'unmentionable devices', it's just that members often send their broken bits to me to have a look at and, as in the case of a squidgy packet that just arrived on my desk, spread the word if there looks like there might be a problem with a component.



Left and above: here is the Kimpex fuel primer bulb that caused a restriction in the fuel supply on the Rans S10. The primer consists of a squeezable rubber bulb and two non-return valves (NRV) to control the direction of flow. (Photo: Malcolm McBride)

Opening this particular package I found a brand new rubber fuel primer. I could tell it was brand new because, unlike many of the fuel-related parts that I receive, Fiona didn't immediately close her office door because of the smell. With the primer, which incidentally looked and felt fantastic, was a compliment slip from Skycraft so I gave Dave Almey, Skycraft's boss, a call. Dave explained that he was inspecting a Rans S10 after its annual maintenance review and that he had decided to replace the fuel primer because the old one was looking past its best. Dave fitted a new primer from stock and checked that it was working correctly and thought no more about it. Later, when the weather improved, Dave began his engine ground runs; everything seemed to be working well and he started to make plans for the test flight. Then the engine stopped. After investigation, it was found that the new primer pump wasn't allowing fuel through under gravity feed. He changed the primer bulb with one from a different manufacturer, ran the engine again, and this time the engine ran perfectly.

Dave checked the suspect primer bulb and realised that this pump was a type new to him. He checked his stock levels and this was the first primer pump from this batch that had been fitted to an aircraft. Phew! Dave has now withdrawn this Kimpex pump from stock and sent an example, off the shelf, to me. Good decisions all round as far as I'm concerned.

The Rans S10, like many very small aircraft, has a relatively simple fuel delivery system. Fuel is contained in two shoulder level wing tanks which are connected

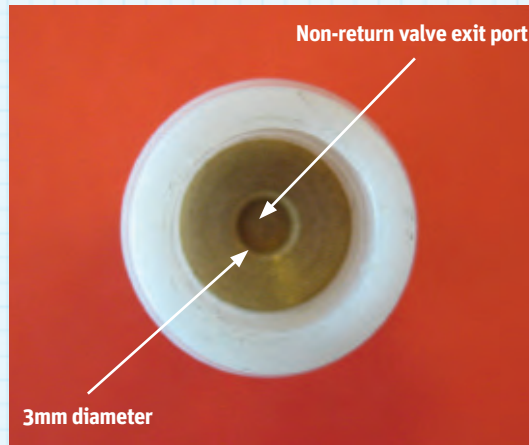

This picture shows an end view of the outlet side NRV. The valve itself is normally held closed by light spring pressure; note that the area upon which the fuel pressure is reacting is very small and the load applied will be proportional to this area. (Photo: Malcolm McBride)

by a balance pipe from which fuel is supplied to the engine via a primer bulb and an ON/OFF fuel tap. At best which, incidentally, is when the aircraft is descending with full tanks, there are only a couple of inches of fuel pressure head available to the engine fuel pump inlet. In the worst case, when the aircraft is sitting on the ground (or climbing with low fuel) the fuel may be required to climb quite a hill.

The Rotax 532 engine fitted to this particular aircraft uses a crankcase pressure-powered pneumatic fuel pump and, providing the lines are free from air, these pumps can provide a significant suction, certainly enough to raise fuel a few feet. This type of pump, however, is very intolerant of air leaks or restrictions in the fuel line.

The photographs and captions explain what I found when I tested the primer bulb

This picture shows the component parts of the Trio autopilot servo; note that if the pin falls out for any reason, the drive arm could come off the shaft and this, in turn, could lead to a primary control jam. (Photo: Malcolm McBride)

and, because Dave used a very careful approach to flight testing this aircraft after maintenance work, the aircraft didn't end up in a field.

It does just show what can happen if you assume that two externally similar components are interchangeable, and both suppliers and purchasers must be on the lookout for gotchas like this. Enough said.

VAN'S RV-10 TRIO AUTOPILOT

Some would say that I spend most of my time on autopilot... no, not the electronic kind, the brain in neutral kind. I often switch on the neural autopilot

during repetitive tasks... mowing the lawn, long drives up the motorway, easy sailing... you know the sort of thing, I'm sure. Being a bit of a purist I would have, a few years ago, pooh poohed the idea of fitting an autopilot to an LAA type of machine. Surely the idea is that you want to do a bit of hands-on flying when you fly an LAA aircraft. Naturally, I have been reprogrammed, and I see the advantages to single-pilot operation (especially during difficult weather) that an autopilot of some sort or another can give to the pilot.

I've got a personal rule that every lunchtime I go for a walk around the airfield

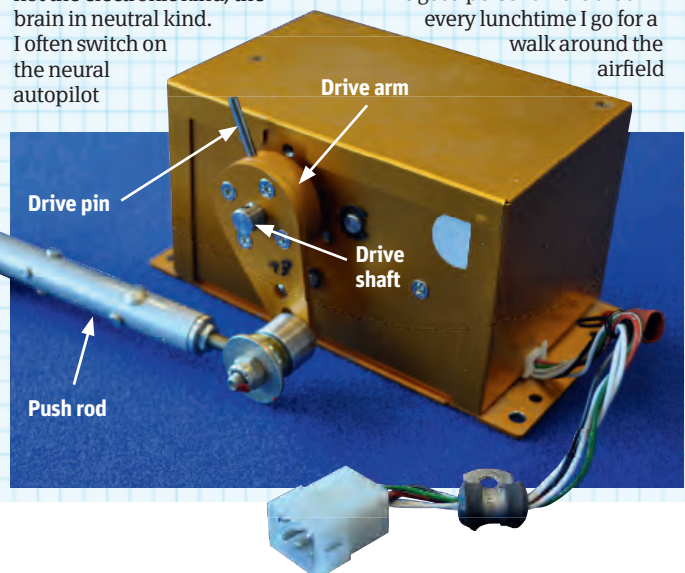

SAFETY SPOT

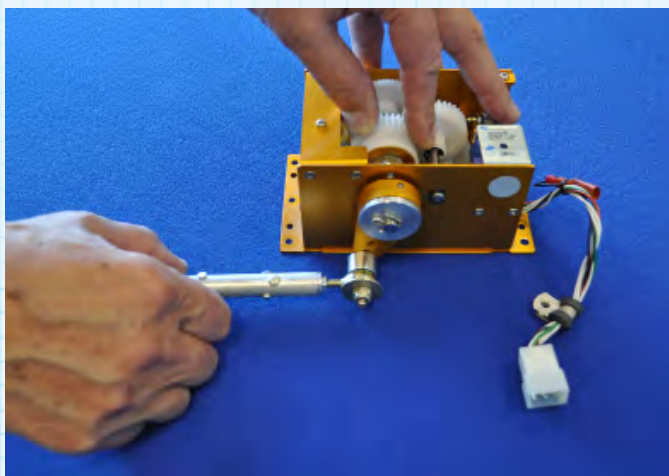
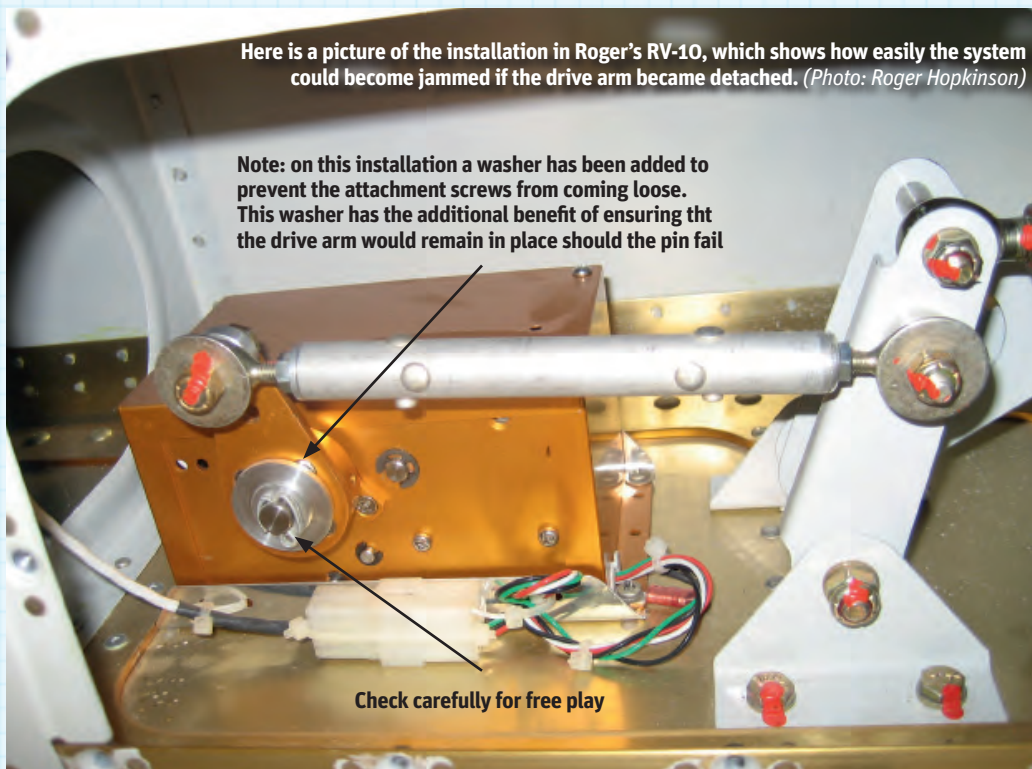

This is an atmospheric shot, more akin to a certain car manufacturer I used to work for. Roger explained that the autopilot fitted to his RV-10 is the Trio EZ system, which includes both heading and altitude-hold functions. The safety features include warnings for minimum and maximum airspeed and a g force limit. Each servo has a clutch, which can be overcome by the pilot should all else fail. It is a testament to modern electronics that this set-up, when coupled to a Garmin or Bendix/King GPS, will fly the aircraft accurately along a pre-determined track at a pre-set altitude. One thing that this unit won't do is adjust the power from the engine... yet. Sounds like armchair flying to me! (Photo: Roger Hopkinson)



boundary. I do it for one reason and that's exercise. I go the same way every day and people have said to me, "Don't you get bored? You must know every stone en route?" They've all missed the point; I don't see any of it as I'm on autopilot!

It was as I returned to my office from one of these lunchtime walks, still on autopilot, I was confronted with an office full of engineer types. At the centre of this small crowd sat a Trio autopilot servo, and the owner of this device happened to be our esteemed Chairman, Roger Hopkinson, who as I'm sure most of you will know, is the owner/ builder of one of the LAA's five flying Van's RV-10 aircraft.

Even with my Luddite tendencies, if ever there was an aircraft on which an autopilot should be considered 'standard kit', it's the RV-10; this is a 200mph aeroplane with a 1,000-mile range. Roger finished building his '10 in 2008 and it has completed about 180 flying hours in the last three years.

When the dust settled and I had disconnected my personal autopilot, Roger explained why the autopilot servo sat on the bench and wasn't in his airframe. He had discovered that the drive pin that secured the operating arm to the autopilot's drive shaft had nearly fallen out and he was very worried by the alarming amount of wear between this shaft and the operating arm. In the first instance, the failure of this connection would mean that drive would be lost from the autopilot - worrisome but probably not a desperate problem as a flight could be hand-flown to destination. The real danger as



far as Roger was concerned was that the arm could wind itself off the shaft and, because it's mechanically connected via a drive rod to the primary control drives, in this case the elevator push rod, under some circumstances the elevator control could become jammed or at very least cause a control restriction. Not a pleasant thought.

Roger, a professional engineer himself, had been worried about the possibility of this arm coming loose because the attaching screws could unwind. He came up with a very simple idea when he built the aircraft to prevent this from happening, using a home-turned aluminium washer held in place on the shaft using a spill pin. You will see when you view the photographs, that this would have the additional benefit of preventing the operating arm from falling off the shaft if the pin should fall out.

The other worrying aspect of this incident is the wear discovered between the shaft and the arm itself. This is not so easy to check, for as the arm and shaft are free to rotate when the autopilot is disengaged. We were able to check this play with the servo's cover removed by fixing the drive cogs; it might be possible to check for play by engaging the autopilot and getting an assistant to move the primary control while you look for any movement in the linkages.

At the time of writing, we're still waiting for the manufacturer's recommendations but, in the meantime, we've written to all the owners who have specifically applied for a mod to fit this autopilot system to their aircraft. In the letter we've made owners aware that there may be a problem beginning to develop with this component. If you own a Trio autopilot on your aircraft and you haven't received a letter may I ask you to let us know here at Engineering HQ that you're not on our list. That way, when we do have specific inspection advice, we can send it to you.

Don't forget, by the way, if you do disturb anything in a primary control system then it is essential that you get an LAA Inspector to check the system before you fly the aircraft.

**PULSAR XP
BLUE STYROFOAM RIBS**

Regular readers of 'Safety Spot' will recall that, in the November edition, I reported a problem where the blue Styrofoam rib infills on a Kitfox aircraft had disintegrated. The consensus was



This is the sight that confronted Paul when he opened up the end rib on a Pulsar XP he is rebuilding. It looks like fuel vapour has encroached into the aft section of the wing from the leading-edge fuel tank vent. This is an early Pulsar XP and the Styrofoam ribs are covered with 1/16in plywood skin which, in turn, is covered with 6oz glasscloth. The foam ribs, while not particularly strong in themselves, are essential in distributing loads around the wing through to the main and rear spars. (Photo: Paul Avery)



In addition to providing a solid structural base for the wing skin, the Styrofoam ribs also support the primary control push/pull rods. This picture of a Pulsar XP failed rib shows a (now unsupported) flap drive bearing. (Photo: Paul Avery)

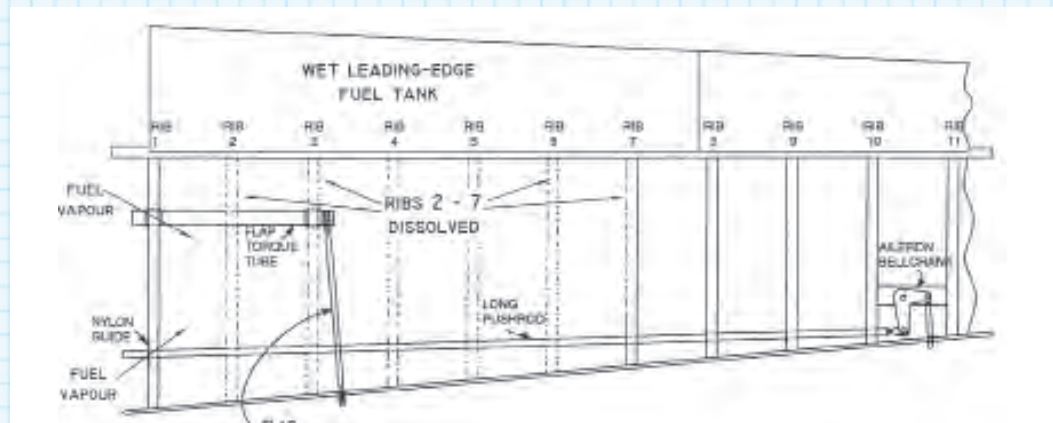

This drawing shows the wing plan form of the Pulsar XP (starboard wing, looking from above). Damaged ribs have been found on ribs 1 through 7 (Drawing: Malcolm McBride)

SAFETY SPOT

that the problem was caused by fuel vapour reacting with the Styrofoam. I then received a call from LAAer Paul Avery who said, "You know that you were talking about Styrofoam and the fact that it doesn't like petrol much..." It might be worth letting Paul tell the story...

The aircraft was advertised on eBay, as requiring 'some TLC'. I'd also seen the aircraft advertised on Afors earlier this year. On the initial visit, I met the owner who was quite happy to allow me to do a full survey on the aircraft. Initial impressions were quite good; all work seemed to be mainly of a cosmetic nature with no major work required before Permit renewal. The aircraft was checked as per TADS (*Type Acceptance Data Sheets, available on the LAA website - MM*) and all seemed in order, however, there seemed to be some flex on the underside of the wing between ribs one and two, which was present on both wings. There was also a slight flex on the walkway, although considerably more pressure had to be applied. On removing the seats and carpets, it was found that the wing-roots were completely sealed with a thin layer of fibreglass painted black, and there was no way I could inspect further.

I arranged to visit again the following day and questioned the owner about this black fibreglass covering. He stated he was aware of it and that it had got no worse during his ownership of the aircraft.

The wings were inspected the following day. Luckily the aircraft was built with two inspection panels on the underside of the wings, one being just outboard of rib three; a snap-on optical borescope was fed through the aileron drive aperture in rib three - ribs one and two on both wings were found to be almost totally dissolved.

The aircraft was purchased and transported to my workshop where the fibreglass covering on the wing-roots was removed and it was found that the damage to the ribs of both wings was almost identical. The fibreglass covering had a very poor bond to the wing-rib epoxy and I don't believe it was part of the original build. In fact, on further investigation, it seems to be a mixture of glass and carbon fibre. There was also some evidence of another substance, perhaps builders foam.

The only area it did have a good bond to was the outer rib 'glass bearing' for the flap torque tube,

hence there was no excessive play on the flaps. The reason for there being more movement on the lower skin is that the walkway is reinforced with a ply/foam sandwich between ribs one and two.'

Paul obviously likes a challenge.

The first thing I did after hearing from Paul was to seek advice about whether this sort of materials failure could be an issue on any of the other LAA machines. The Rutan designs came to mind as Styrofoam was the material of choice for the VariEze and Long-EZ aircraft. I emailed Don Foreman, a LAA Inspector who specialises in these machines. He said that he had never seen a problem with any of the machines that he had inspected, but it was well-known that fuel and Styrofoam didn't mix. Perhaps it would be more technically correct to say that fuel and Styrofoam mix rather well, in any event my next stop didn't require me to travel far, just to the next office in fact!

The reason for getting out from under my desk was that I knew that the Europa aircraft used blue Styrofoam in its construction. Who better to ask about Europas than the LAA's Design Engineer, Andy Draper. He used to be a Senior Engineer at the Europa factory when they were designing the machine and still keeps a very close eye on the type. Andy agreed with Don that there was

no real cause for concern as far as the Europa fleet was concerned because the fuel tank in the Europa is in the fuselage and the main use of Styrofoam is in the tail surfaces and the wings of the original 'Europa Classic' model. In the Pulsar XP, on the other hand, the foam wing ribs are just inches away from the fuel tanks which are of 'integral' type, occupying the whole length of the inboard leading-edges portion of the wings.

We've seen this problem before on Pulsars and, in 2001, the PFA issued an Airworthiness Information Leaflet (AIL) requiring a one-off check of the wing ribs. This early AIL was in response to a flap failure caused by the collapse of the wing rib supporting the flap torque tube. Actually, the wing rib had completely disappeared!

The wing ribs, albeit only soft foam, are an essential part of the structure on the Pulsar aircraft; failure of these ribs could lead to a structural deficit and a possible wing failure. Clearly, regular inspections are required and these have now been called-up by the reissue of the LAA's ALL. This is a good example of the need for a thorough inspection of the aircraft's structure at regular intervals and we now require internal structural checks on the Pulsar aircraft at each annual inspection. This particular machine was first Permitted 20

years ago and had accumulated about 300 hours in this time, a little over an hour a month! Thanks Paul for letting us know about the problem and good luck bringing this lovely aircraft back to full serviceability.

82A TIGER MOTH FUEL HOSES

Just as I was coming to the end of my draft for 'Safety Spot', Francis Donaldson, the LAA's Chief Engineer, asked me whether I had seen the latest Technical News Sheet (TNS) from de Havilland Support Ltd (DHSL). I hadn't, but he said that I should read it because it highlighted to him how careful we must all be when designing or changing maintenance schedules to suit LAA Permit operation. The TNS Francis gave me concerned flexible fuel hoses, a subject that we've spent some time on in 'Safety Spot' over the years.

The reason DHSL issued the TNS is that it was becoming more than a little concerned that some of the fuel hoses fitted to Moth aircraft could date back to the 1940s and should, after over 70 years operation, be considered suspect and retired from service. We belong to an organisation where age alone wouldn't normally be considered a reasonable criterion for scrapping parts, but I agree with Mark Miller, DHSL's Chief Engineer, that natural, rubber-based products



Here is a picture of a Superflexit fuel hose that has been removed from a DH 82A Tiger Moth. There's a good chance that this fuel hose has been performing well for sixty or seventy years but nature demands that these natural rubber components will have a life. Rubber tends to harden with age and you will notice that a flexible item retains its 'fitted' shape when removed. The reduction in flexibility in a fuel pipe can lead to cracking, which may not be visible from the outside of the pipe; this, incidentally, could result in a sudden failure at any time. I always thought that the wire wound around this sort of pipe was to increase the pipe's pressure tolerance and resistance to kinking, and was surprised to hear that the wire is there to provide an electrical conductor.

(Photo: de Havilland Support Ltd)



will have a service life and that a sensible approach to managing their life should be taken into account when you design the maintenance programme for your machine.

Strangely, the rules governing fuel hoses are quite simple and, unless a particular manufacturer defines a service life of a part (and many do) hoses are judged as an 'On Condition' item. I would be surprised if a 70-year-old rubber hose would still meet the 'On Condition' 36-month pressure test requirement stated in the UK CAA's Light Aircraft Maintenance Programme (LAMS) and remember, the maintenance schedule that you use will almost certainly use LAMS as its basis.

The hoses that DHSL suggests are suspect are Superflexit, Avioflexus and Pertroflexus types and, while they may look OK from the outside, internal deterioration and loss of flexibility is almost inevitable. DHSL recommends that all these older types of pipe should be replaced with modern equivalents and recommends that fuel hoses should be replaced with new items every 15 years.

Interestingly, and this should remind us all that taking things for granted in the aviation world is never a sensible operating strategy, the old de Havilland-supplied fuel pipes were externally wire-braided types which also acted as an electrical earth between the carburettor and the petrol filter. DHSL's TNS provides details of a simple bonding strap that must be added between engine and airframe when swapping to a modern Aeroquip-type hose, which has no such metal braiding. Good Spot DHSL! Fair winds! ■

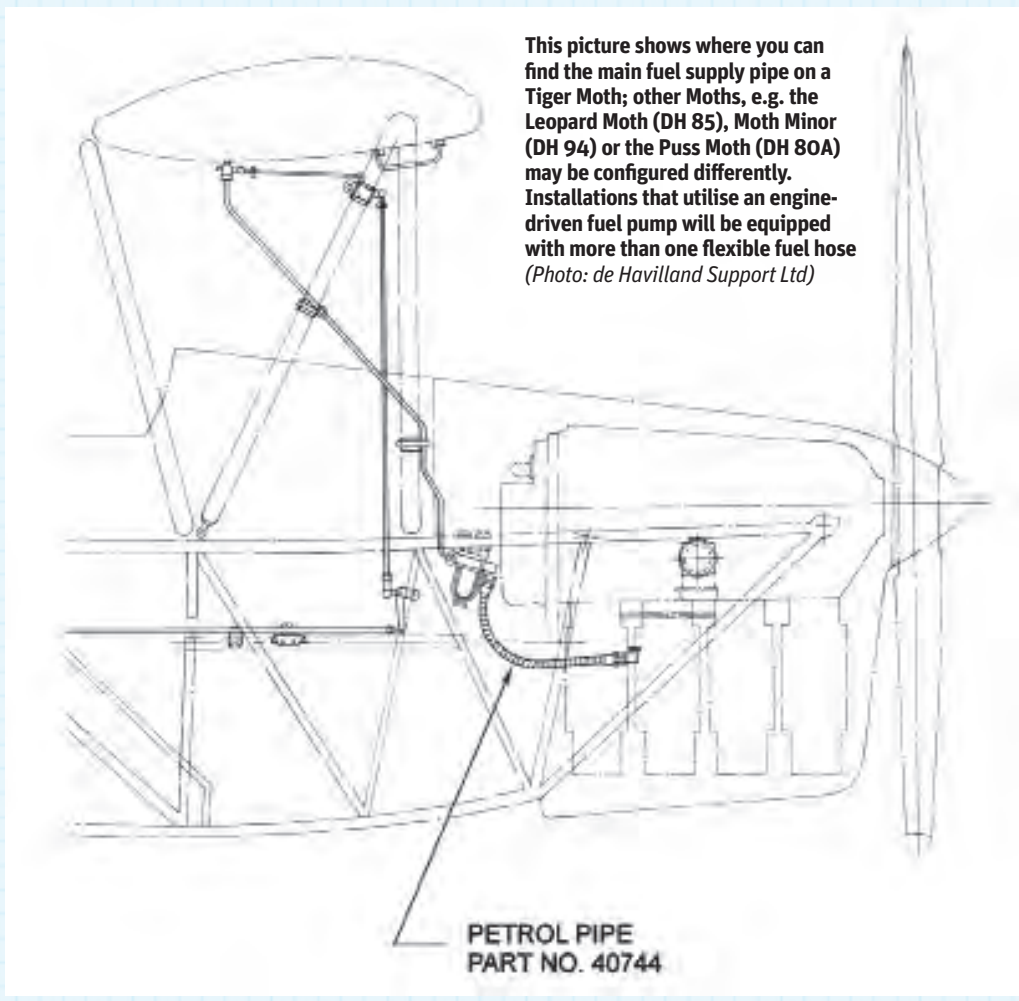

This picture shows where you can find the main fuel supply pipe on a Tiger Moth; other Moths, e.g. the Leopard Moth (DH 85), Moth Minor (DH 94) or the Puss Moth (DH 80A) may be configured differently. Installations that utilise an engine-driven fuel pump will be equipped with more than one flexible fuel hose (Photo: de Havilland Support Ltd)



Here's a close-up of a carburettor flange from a picture I featured in December's *Light Aviation*. LAA Inspector Robin Dispain wrote to me pointing out that gasket sealant had been used during the assembly and that this shouldn't have been necessary. Robin made a good point, which I promised to share. If there's excess sealant on the outside then there's a good chance that there will be excess on the inside. Food for thought! (Photo: Barry Smith)

LAA ENGINEERING SCALE OF CHARGES

LAA Project Registration

Kit Built Aircraft	£300
Plans Built Aircraft	£50

Issue of a Permit to Test Fly

Non-LAA approved design only	£40
------------------------------	-----

Initial Permit issue

Up to 390kg	£320
391 - 499kg	£425
500kg and above	£565
Three seats and above	£630

Permit renewal

Up to 390kg	£105
391 - 499kg	£140
500kg and above	£190
Three seats and above	£210

Modification application

Prototype modification	£45
------------------------	-----

Repeat modification	£22.50
---------------------	--------

Transfer

(from CofA to Permit or CAA Permit to LAA Permit)	
---	--

Up to 499kg	£135
-------------	------

500 kg and above	£250
------------------	------

Three seats and above	£350
-----------------------	------

Four-seat aircraft

Manufacturer's/agent's type acceptance fee	£2,000
--	--------

Project registration royalty	£50
------------------------------	-----

Category change

Group A to microlight	£135
-----------------------	------

Microlight to Group A	£135
-----------------------	------

Change of G-Registration fee

Issue of Permit Documents following G-Reg change	£45
--	-----

Replacement Documents

Lost, stolen etc (fee is per document)	£20
--	-----

Latest SPARS - April 2009