

FUEL SYSTEM.

IMPORTANT SPECIFICATIONS.

IMPULSE HOSE LENGTH:	MAXIMUM	150mm.
IMPULSE HOSE INSIDE DIAMETER:	MINIMUM	5mm.
FUEL INLET HOSE LENGTH	MAXIMUM	2000mm.
FUEL INLET HOSE INSIDE DIAMETER MINIMUM		5mm.
HEIGHT OF FUEL LIFT THROUGH INLET HOSE	MAXIMUM	1000mm.
OUTLET HOSE LENGTH	MAXIMUM	500mm.
OUTLET HOSE INSIDE DIAMETER	MINIMUM	5mm.
OUTLET HOSE HEIGHT	MAXIMUM	100mm.

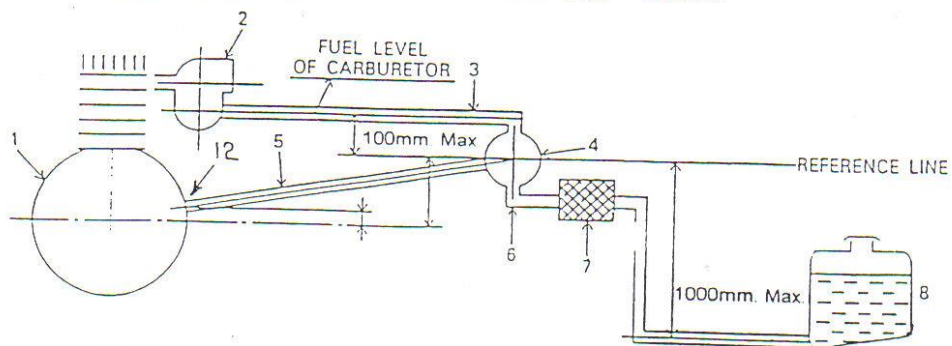

1. ENGINE
2. CARBURETTOR
3. OUTLET HOSE
4. FUEL PUMP
5. IMPULSE HOSE
6. INLET HOSE
7. FUEL FILTER
8. FUEL TANK